

GB

01

THE NEW GENERATION!



⇒ COMPRESSED AIR FILTERS  
AND WATER SEPARATORS

INTELLIGENT AIR TECHNOLOGY

CompAir compressed air filters are designed to provide the most energy efficient filtration solutions available.

Low operating pressure drops mean that your compressor can operate at a lower working pressure than would be required with other filters. Lower working pressures result in reduced energy consumption. For example, a 2% reduction in working pressure results in a 1% saving in compressor energy costs.

Alocrom & dry power epoxy coated filter housing for full corrosion protection.



### ➔ NEW FILTRATION TECHNOLOGY

CF\_N compressed air filters use very little energy as they have a low resistance to air flow. Advancements such as deep bed pleating, graded density media and an oleophobic coating have led to a high performance filter element with low initial energy costs. Differential pressure starts low and stays low throughout its life. Service life is no longer dependent upon differential pressure, but on annual filter element change backed up with a one year air quality guarantee.

**AEROSPACE TURNING VANES**  
Turning vanes effectively direct air flow into the filter element.



**AIR STABILISERS**  
Smooth outlet air flow.

**SPECIAL FILTER MEDIA**  
Oleophobic nanofibre filter media actively repels oil and water to reduce pressure drop and keep running costs to a minimum.



Filter media actively repels oil and water.

**HIGH EFFICIENCY DRAINAGE LAYER**  
Ensures coalesced liquids are removed quickly and efficiently.



**DRAINAGE RIBS**  
Filter housing and element integrate to provide capillary action which greatly improves liquid drainage. Interaction between housing and element also ensures maximum coalescing performance is achieved at all times.

**NO WET BAND FORMATION**  
Allows 40% more air flow through a smaller filter element.

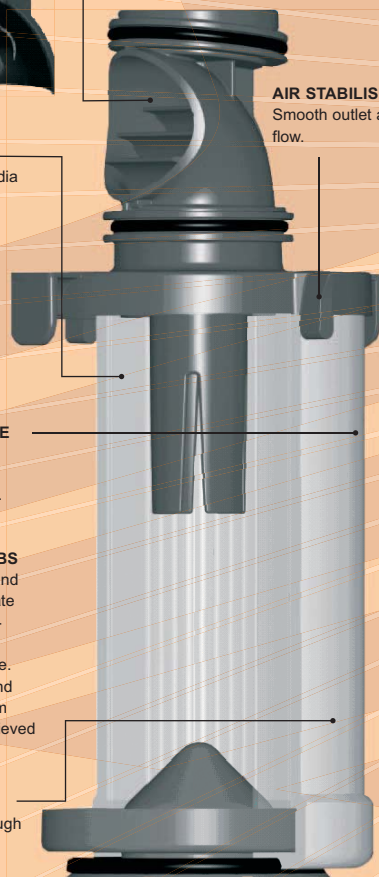

Filter Pressure Loss

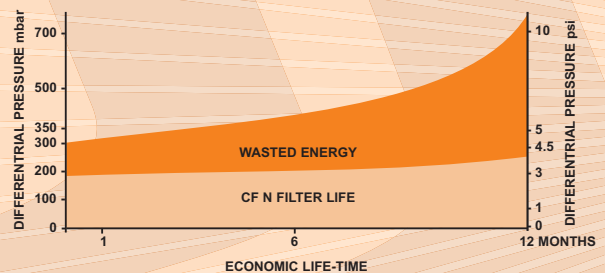

Compressed Air Quality & Product Selection  
Compressed Air Quality to ISO 8573.1

CLASS	Solid Particle Maximum number of particles per m <sup>3</sup>			Water Pressure Dewpoint °C	Oil (incl. Vapour) mg/m <sup>3</sup>
	0.1–0.5 micron	0.5–1.0 micron	1.0–5.0 micron		
1	100	1	0	-70	0.01
2	100,000	1,000	10	-40	0.10
3	–	10,000	500	-20	1.00
4	–	–	1,000	+3	5.00
5	–	–	20,000	+7	–
6	–	–	–	+10	–

## ⇒ 5 FILTER VARIANTS AVAILABLE

To meet varying requirements, CompAir filters are available in five filter variants:

### TYPE B: HIGH EFFICIENCY GENERAL PURPOSE PROTECTION

Particle removal down to 1 micron, including water and oil aerosols. Maximum remaining oil aerosol content: 0.6 mg/m<sup>3</sup> at 21 °C/0.5 ppm(w) at 70 °F.

### TYPE C: HIGH EFFICIENCY OIL REMOVAL FILTRATION

Particle removal down to 0.01 micron, including water and oil aerosols. Maximum remaining oil aerosol content: 0.01 mg/m<sup>3</sup> at 21 °C/0.01 ppm(w) at 70 °F.

### TYPE D: OIL VAPOUR & ODOUR REMOVAL

Maximum remaining oil vapour content: 0.003 mg/m<sup>3</sup> at 21 °C/0.003 ppm(w) at 70 °F.

### TYPE E: GENERAL PURPOSE DUST FILTRATION

Dry particle removal down to 1 micron.

### TYPE F: HIGH EFFICIENCY DUST FILTRATION

Dry particle removal down to 0.01 micron.

## ⇒ ADVANCED FILTER HOUSINGS



### COMPACT & LIGHTWEIGHT

Advanced housing and element design has also provided a smaller, more compact and lightweight filter which is quick, easy and clean to maintain.

### MINIMAL SERVICE CLEARANCE

Space saving design minimises service clearance and allows installation in confined spaces.



### “Clean Change” Filter Element

Element changes are now easy and do not require the user to touch the contaminated element during annual element change.



No corrosion with Alocrom treatment



Rapid corrosion of untreated Aluminium



### FILTER CONNECTIONS

More port sizes are available to match both pipe size and system flow rate giving additional customer choice.

### FULLY CORROSION PROTECTED

Alocrom & dry powder epoxy coated for full corrosion protection.

## ⇒ OPTIONS



### Incident monitor (optional)

Used to indicate premature high differential pressure. Indicator can be retrofitted to existing housings without depressuring the system.



### FIXING CLAMP

Joins two filters and is a wall mounting bracket in one.



Float drain



Electronic drain

### CHOICE OF DRAINS

Manual, float and electronic drain options available. Easy connection with standard fittings via 1/2" threaded drain port.

FILTER TYPE	PORT SIZE	FLOW RATE <sup>1)</sup>		DIMENSIONS		WEIGHT	ELEMENT TYPE	REPLACEMENT ELEMENT KIT NO. FILTER GRADE			NUMBER OF ELEMENTS
		at 7 bar g / 100 psi g		LENGTH	HEIGHT			B+E	C+F	D	
		m <sup>3</sup> /min	scfm	mm/in	mm/in	kg/lb					
CF0006N 1/4" (+Grade)	1/4"	0.6	21	76/3.0	181.5/7.12	0.4/0.88	CE0006N + Grade	A51128374	A51128474	A51128574	1
CF0006N 3/8" (+Grade)	3/8"										
CF0006N 1/2" (+Grade)	1/2"										
CF0012N 3/8" (+Grade)	3/8"	1.2	42	97.5/3.8	235/9.3	1/2.2	CE0012N + Grade	A51128874	A51128974	A51129074	1
CF0012N 1/2" (+Grade)	1/2"										
CF0018N 1/2" (+Grade)	1/2"	1.8	64	97.5/3.8	235/9.3	1/2.2	CE0018N + Grade	A51129374	A51129474	A51129574	1
CF0018N 3/4" (+Grade)	3/4"										
CF0006N 1" (+Grade)	1"										
CF0036N 3/4" (+Grade)	3/4"	3.6	127	129/5.1	274.8/10.8	2.2/4.84	CE0036N + Grade	A51129874	A51129974	A51130074	1
CF0036N 1" (+Grade)	1"										
CF0066N 1" (+Grade)	1"										
CF0066N 1 1/4" (+Grade)	1 1/4"	6.6	233	129/5.1	364.3/14.3	2.6/5.72	CE0066N + Grade	A51130374	A51130474	A51130574	1
CF0066N 1 1/2" (+Grade)	1 1/2"										
CF0096N 1 1/4" (+Grade)	1 1/4"	9.6	339	170/6.7	432.5/17	4.5/9.9	CE0096N + Grade	A51130874	A51130974	A51131074	1
CF0096N 1 1/2" (+Grade)	1 1/2"										
CF0132N 1 1/2" (+Grade)	1 1/2"										
CF0132N 2" (+Grade)	2"	13.2	466	170/6.7	524.5/20.6	5.25/11.55	CE0132N + Grade	A51131374	A51131474	A51131574	1
CF0198N 2" (+Grade)	2"										
CF0258N 2 1/2" (+Grade)	2 1/2"	25.8	911	204.8/8.1	641.6/25.3	10/22	CE0258N + Grade	A51132374	A51132474	A51132574	1
CF0258N 3" (+Grade)	3"										
CF0372N 2 1/2" (+Grade)	2 1/2"	37.2	1314	204.8/8.1	832.1/32.8	12/26.4	CE0372N + Grade	A51132874	A51132974	A51133074	1
CF0372N 3" (+Grade)	3"										
CF0600N 4" (+Grade)	4"	60	2119	204.8/8.1	832.1/32.8	X	CE0600N + GradeF	A51133374	A51133474	A51133574	3
<b>FLANGED HOUSINGS <sup>2)</sup></b>											
CF0132N (+Grade)F	DN50	13.2	466	304/12	800/31.5	32.5/72	CE0132N + GradeF	A51133874	A51133974	A51134074	1
CF0258N (+Grade)F	DN80	25.8	911	370/4.6	980/38.6	60/132	CE0258N + GradeF	A51134374	A51134474	A51134574	1
CF0372N (+Grade)F	DN80	37.2	1314	370/16.6	1220/48	70/154	CE0372N + GradeF	A51134874	A51134974	A51135074	1
CF0600N (+Grade)F	DN100	60	2119	500/19.7	1325/52.2	150/330	CE0600N + GradeF	A51133374	A51133474	A51133574	3
CF0780N (+Grade)F	DN100	78	2755	500/19.7	1325/52.2	150/330					4
CF1170N (+Grade)F	DN150	117	4132	580/22.8	1424/56.1	200/440					6
CF1950N (+Grade)F	DN200	195	6886	750/29.5	1687/66.4	400/880					10
CF3120N (+Grade)F	DN250	312	11018	862/33.9	1821/71.7	540/1188					16
CF4680N (+Grade)F	DN300	468	16527	1000/39.4	1910/75.2	700/1540					24

CF N FILTER GRADE	INITIAL DIFFERENTIAL PRESSURE		FILTRATION	PRESSURE MAX.	RECOMMENDED TEMPERATURE
	dry mbar/psi	wet mbar/psi			
B <sup>3)</sup>	70/1	0.6	wet	16/232	1.5-80/35-176
C <sup>3)</sup>	100/1.5	200/3			
D <sup>3)</sup>	70/1	N/A	dry	20/290	1.5-50/35-122
E <sup>3)</sup>	70/1		dry	20/290	1.5-100/35-212
F <sup>3)</sup>	100/1.5				

<sup>1)</sup> For flowrates at other temperatures, apply the correction factor shown:

LINE PRESSURE	bar g	1	2	3	4	5	6	7	8	9	10	11	12	13	14	15	16
	psi g	15	29	44	58	73	87	100	11+	131	145	160	174	189	203	218	232
<b>CORRECTION FACTOR</b>		0.38	0.53	0.65	0.76	0.85	0.93	1.00	1.07	1.13	1.19	1.25	1.31	1.36	1.41	1.46	1.51

<sup>2)</sup> Fabricated housings flanged to BS 4504 PN16 and designed to CEN 286 Part 1 (1991). Other pressure vessel standards available.

<sup>3)</sup> supplied with float drain / optional electronic drain

<sup>4)</sup> supplied with manual drain

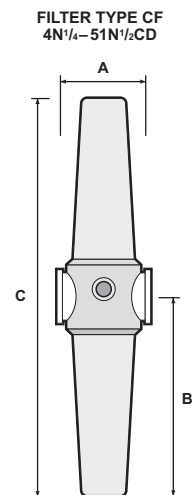
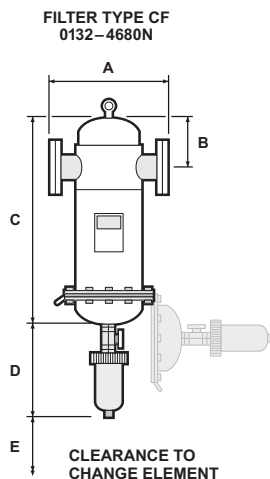
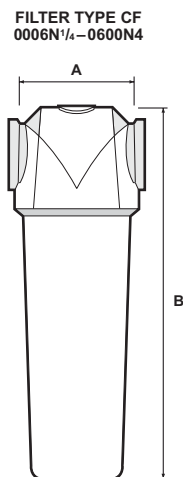

DATA ON DEMAND